

THE FLOW SCIENCES SAF T FLOW™ FUME HOOD SERIES



- OVERLAPPING SASH BYPASS PROVIDES BETTER CONTAINMENT AND DOES NOT REQUIRE CHANGES IF VAV IS INSTALLED
- SAVE OVER 60% OF ENERGY WITH THE SAF T FLOW™ FUME HOOD SERIES
- GREAT ANSI/ASHRAE 110 CONTAINMENT RESULTS UNDER A WIDE RANGE OF CONSTANT VOLUME AND VAV CONDITIONS

DESIGN. Uniquely designed for safety and convenience, the Saf T Flow features include a different kind of bypass system that assures all air entrained by the hood is actively used to engage, contain, and exhaust fumes from the containment area. High efficiency allows a high degree of energy saving which saves lots of money.

SAFETY. The SAF T FLOW™ series provides safety from chemical vapors generated during chemical processes including reflux, distillation, flash chromatography, evaporation, and other process equipment applications.

FLEXIBILITY. SAF T FLOW™ uses the same overall design structure in all standard fume hood sizes to maximize simplicity in lab planning, layout, and HVAC coordination. This approach allows any popular low-flow exhaust option without requiring expensive retrofits to the hood.

SLIDE-OUT TOP SYSTEM. Sometimes tops shatter. The slide-out feature allows complete top replacement without lifting the fume hood superstructure and disconnecting plumbing and ductwork.

STABILIZING BAFFLE CONTROL SYSTEM. Slots oriented in both X and Y axis promote even air flow back into the hood interior from top to bottom of the sash opening. The rear baffle is also removable for easy cleaning.

QUICK-SET SCAFFOLDING SYSTEM. Detachment knobs make for quick scaffolding setup and easy rear baffle removal for cleaning.

CLEAR CORD FLIP-UP AIRFOIL. Used for safe cord routing and air flow direction.

HEAVY GAUGE SUPERSTRUCTURE AND CHAIN DRIVE. 14 and 18 gauge framing system and #35 steel chain drive will run 500,000 cycles without breaking.

FEATURES & BENEFITS

- 1 CHAIN DRIVE** - #35 Heavy grade chain drive that will not break for over 500,000 cycles



- 2 HEAVY GRADE SUPERSTRUCTURE** - 14 and 18 gauge framing system assures superstructure stability

- 3 OSB** - Overlapping Sash Bypass system allows for great containment and VAV flexibility



- 4 QUICK-SET SCAFFOLDING** - Quick removal detachment knobs for baffle removal and easy scaffolding setup

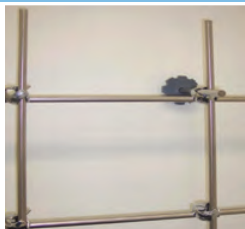

- 5 SASH FLANGE** - Angled flange sends the downward air from the OSB rearward to improve containment and air flow

- 6 FLIP-UP AIRFOIL** - Bottom airfoil flips down for cord routing and directs air for laminar air flow across the work surface

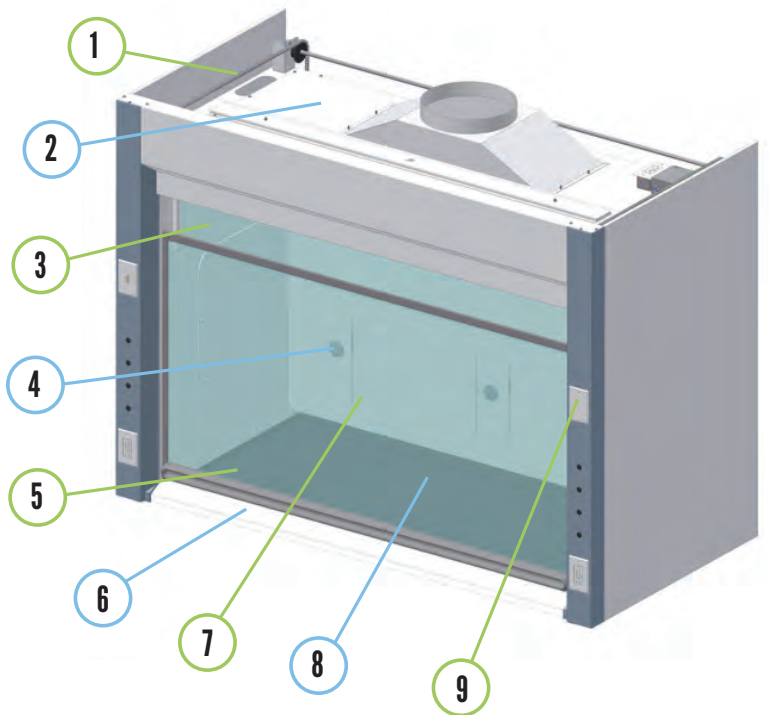

- 7 STABILIZING REAR BAFFLE** - Allows for easier cleaning and includes X and Y axis slots to promote even airflow



- 8 SLIDE-OUT BASE TOP** - Makes broken top replacement simple without having to lift the fume hood superstructure



- 9 CONTROLS & PLUMBING** - All standard plumbing types are available on Saf T Flow fume hoods. Our Broen fittings with flexible tubing allow pre-plumbing with pre-fitted female threaded connectors to existing house services. This tubing system resists shipping vibration issues which some times requires re-soldering hard copper, pre soldered and pre-plumbed services.

OVERLAPPING SASH BYPASS (OSB)



The overlapping sash bypass provides better containment and never needs to be removed or replaced if Variable Air Volume conservation systems are retrofitted into an existing Saf T Flow installation. In all exhaust applications, bypass air does productive work clearing fumes from behind the sash and means all exhausted air does containment work at all times, with any exhaust strategy.

Keep in mind, volumetric reductions in fume hood exhaust can save thousands of energy dollars each year on each hood. This is the main reason traditional constant volume hoods have been frequently converted to VAV to save exhaust air and energy.

We have tested our OSB from 100 FPM full open sash down to 60 FPM at 18" sash opening with ASHRAE 110 containment equipment and cannot tell any difference in containment performance at any selected face velocity or opening within this range. Breathing zone containment ranged from 0.005ppm down to undetectable. Fantastic containment at very low exhaust volumes!

We have stunning video of our air flow patterns online at www.flowsciences.com.



FLOOR MOUNTED FUME HOODS

The Saf T Flow floor mount hood is used for applications requiring much larger set-ups.

Bulk reflux or distillations, roll-in racked procedures, and kilo-quantity syntheses are all examples of applications which may require such hoods.

The need for sturdy, chain drive sash operation, a versatile sash opening (top or bottom), and an extremely rugged painted steel containment box with FRP liner are all features in this stand alone unit. All walk-ins are sized for 50% open. OSB Bypass is standard.

FUME HOOD BASE CABINETS FOR ALL APPLICATIONS



STANDARD FUME HOOD BASE CABINETS:

- Epoxy-painted steel construction
- Single intermediate shelf supplied

SOLVENT CABINETS :

- Single intermediate shelf supplied
- Double Steel Wall Construction
- All flammable cabinets are built according to the construction standards expressed in NFPA 30: section 9.5.2(2)

CORROSIVES CABINETS:

- Epoxy-painted steel construction
- Interior lined with 3mm FRP panel
- Single intermediate shelf supplied

CUSTOM HOODS

Flow Sciences has a team of engineers that will work with you to design and manufacture a custom containment solution for your specific application.

After production, FSI tests these enclosures in a laboratory on site, and can also arrange 3rd party testing on site for Factory Acceptance Testing.



GO TO FLOWSCIENCES.COM OR SCAN THE QR CODE TO LEARN MORE ABOUT THE SAF T FLOW™ FUME HOOD AND WATCH THE NEW FUME HOOD VIDEOS!

FLOWSCIENCES.COM

